

## Low Voltage Variable Frequency Drive

Range: 0.2 kW to 2.2 kW

## HH10 Series

Low Voltage Drive



Most Energy Efficient Means of Process Control

## About HH10 Series Low Voltage Drive

HH10 series Economic drive is new generation of general-purpose inverter with rich features, wide-power range and widely used in Fan, water pump speed control and conveyor applications. Products are based in latest TI 32-bit DSP which gives highly accurate motor auto-tuning, high-speed control and improves reliability of the product.

## Advantages

Independent air duct design



Multi-function and easy to use

TUV SUD and reliable quality assurance

## Features

### V/f control

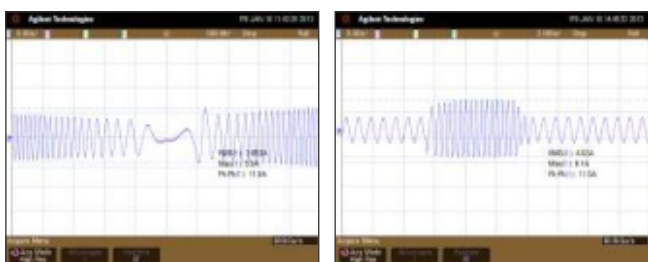

### Natural cooling (for the applications with cotton and dust)



### Mini structure, less installation space



### Various function setting

1. Standard Modbus communication
2. Built-in PID
3. 16 steps multi-step speed control
4. Flexible V/f curve setting
5. Multi-function I/O terminal (the delay time can be set)
6. Fault protection at overcurrent overvoltage, undervoltage, overtemperature and overload with detailed fault information
7. DC braking, flux braking and inbuilt dynamic braking
8. Overcurrent and overvoltage stall, stronger load adaptability

## Technical Specifications

Function	Specification
Input Voltage (V)	Single phase 220 (-15%)~240 (+10%) Three phase 220 (-15%)~240 (+10%) Three phase 380 (-15%)~440 (+10%)
Input Frequency (Hz)	50 Hz or 60 Hz    Allowed range: 47~63 Hz
Output Voltage (V)	0-input voltage
Output Frequency (Hz)	0-400 Hz
Control Mode	V/f
Maximum Output Frequency	400 Hz
Adjustable-speed Ratio	1:100
Overload Capability	150% of rated current: 1 minute, 180% of rated current: 10 seconds, 200% of rated current: 1 second
Terminal Analog Input Resolution	≤ 20 mV
Terminal Switch Input Resolution	≤ 2 ms
Analog Input / Output	1 input 0~10 V / 0~20 mA; 1 output 0~10 V / 0~20 mA
Digital Input / Output	5 common input, 1 Y output (commonly used with digital output) and 1 programmable relay output
Communication	485 communication
Mountable Method	Wall mountable
Temperature of the Running Environment Cooling	-10~50°C, derate above 40°C
Cooling	Single / three-phase 200 V 0.2-0.75 kW natural cooling Single / three-phase 200 V 1.5-2.2 kW, three-phase 400 V 0.75-2.2 kW air-cooling
Fault Protections	Overcurrent, overvoltage, undervoltage, overtemperature, overload and other protections
Braking Unit	Standard for all HH10 series models

## Type Designation Key

HH10 - 2R2 - 4

①      ②      ③

Sign	Detailed description of the sign
①	Drive Series Name
②	Power Rating in kW
③	Voltage Class: 2-200 V, 4-400 V

## Power Rating

	Model	I continuous (A)	P (kW)
200 V Class	HH10-0R2-2	1.6	0.2
	HH10-0R4-2	2.5	0.4
	HH10-0R7-2	4.2	0.7
	HH10-1R5-2	7.5	1.5
	HH10-2R2-2	11	2.2
400 V Class	HH10-0R7-4	2.5	0.7
	HH10-1R5-4	4.2	1.5
	HH10-2R2-4	5.5	2.2

## Wiring Diagram of Main Circuit

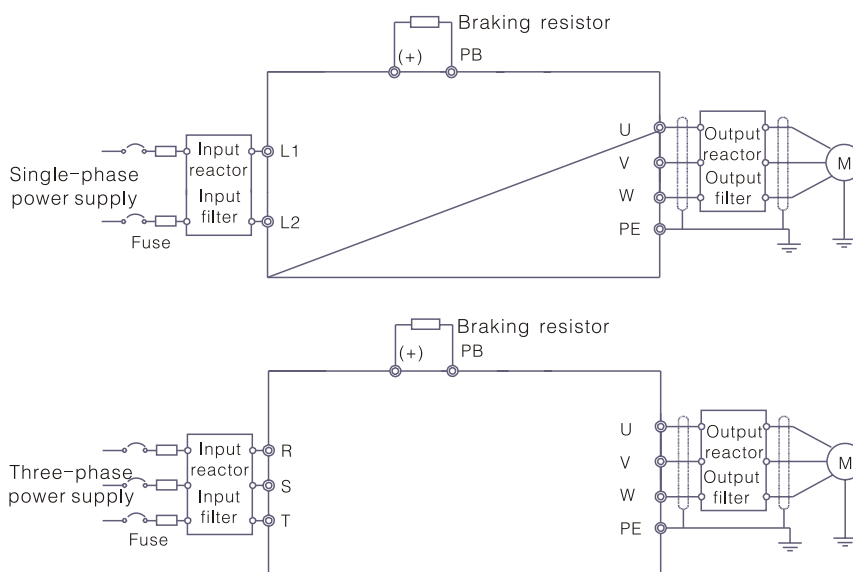

## Product Weight and Dimensions

Voltage	Power	Gross Weight (kg)	Net Weight (kg)	Packing Material	Dimension (mm)
1 AC 200 V	0.2~0.4 kW	1.4	1.1	Carton box	190 x 135 x 235
	0.7~2.2 kW	1.7	1.3	Carton box	230 x 160 x 230
3 AC 200 V	0.2~0.7 kW	1.4	1.1	Carton box	190 x 135 x 235
	1.5~2.2 kW	1.7	1.3	Carton box	230 x 160 x 230
3 AC 400 V	0.7~2.2 kW	1.7	1.3	Carton box	230 x 160 x 230

## Installation Dimension

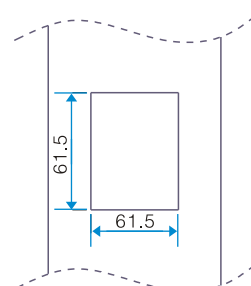
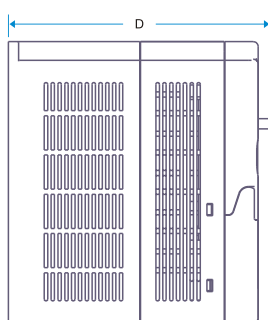
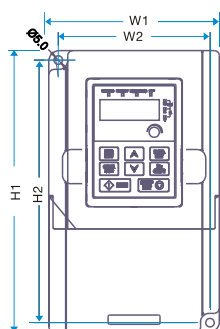

Installation bracket

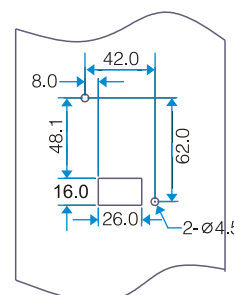

Installation of keypad screw

Voltage	Model	W1(mm)	W2(mm)	H1(mm)	H2(mm)	D(mm)
1 AC 200 V	HH10-0R2-2	85	75	140	132	134.2
	HH10-0R4-2					
	HH10-0R7-2	100	89	165	154	
	HH10-1R5-2					
3 AC 400 V	HH10-2R2-2	100	89	165	154	153.2
	HH10-0R7-4~ HH10-2R2-4					

## Serving Entire Gamut of Industries

We have rich experience in supplying power electronics products for mission critical applications in various industries for critical data processing applications and back-up technology for demanding applications.



### Plastic

- Extruder
- Compressor
- Injection moulding
- Tape Line Machin



### Textile

- Ring frame
- Compressor
- Spinning mill
- Winder
- Cooling fan
- Doubling machine
- Stentar Machine



### Food and Beverages

- Compressor
- HVAC
- Packing



### Power

- ID Fan, FD Fan, PA Fan
- Pump
- Compressor
- Conveyors
- Cooling Tower



### Steel & Mining

- Fan
- Ball mill
- Pump
- Conveyors
- Crane
- Wire Drawn Machine
- Roller Table
- Crusher
- Vibro Feeder



### Cement

- Fan
- Mixture
- Ball mill
- Crusher
- Conveyors
- Kiln



### Ceramic

- Ball mill & Blunger
- Compressor
- Spay dryer blower
- Kiln blowers
- Agitator motor
- Hydraulic press
- Conveyors



### Chemical

- Centrifugal pump
- Compressor
- Fan
- Agitator



### Pulp & Paper

- Pump
- Dryer
- Pop Reel
- Press
- Sectional Roll
- Rewinder
- Refiner
- Pulper

and many more...

## About Hitachi Hi-Rel Power Electronics

Founded & established in 1983 as Hi-Rel Electronics Pvt. Ltd., which later on in year 2015 had become the 100% subsidiary company of Hitachi, Japan which is one of the Global fortune 500 companies with a new name as Hitachi Hi-Rel Power Electronics Private Limited, which is being recognized as one of the pioneers in power electronics domain. Hitachi Hi-Rel, today, is a leading manufacturer of Industrial UPS, IT & Infra UPS, Medium & Low Voltage Variable Frequency Drives, Grid Tied Solar Inverters, Air Compressors and Railway Inverters.

Hitachi Hi-Rel has state-of-the art manufacturing facility at Sanand near Ahmedabad in Gujarat-India. Hitachi Hi-Rel is helping a wide array of industries and organizations to meet the mission critical demands through technologically superior, low polluting and innovative products Solutions and continue to offer world class power electronics products, value added services & customized solutions.

With a vision of “To be recognized as the most trusted Power Electronics Company by supplying superior products and services”, Hitachi Hi-Rel has garnered a significant level of trust in Indian power electronics market segment wherein it serves the entire gamut of Industries, particularly in mission critical applications for Refineries, Petro-Chemicals, Power Generation, Steel & Metals, and Process Industries as well as Critical Data Processing Applications. Besides offering greater energy efficiency & lower carbon footprint, each of the company product streams bears the hallmark of excellence with company accreditations. Hitachi Hi-Rel is an ISO 9001:2015, ISO 14001:2015 & ISO 45001:2008 certified company having export house status. Hitachi Hi-Rel sales network & service infrastructure expands out to the world & with this network, we have made strong inroad in Global markets like South East Asia, Middle East, Africa and Brazil. Also, with a presence of strategically located skilled service engineers in India helps us to score high in terms of customer expectations on service deliverables & uptime of the product.

Hitachi Hi-Rel's UPS and power conditioning back-up systems, the flagship product, works as an exceptional safeguard against power disruption and reflects the industry's ultimate in advanced technology with proven track record in mission critical applications. Its variable frequency drives represent the most energy efficient means of process control and reflect the best in

process control. Hitachi Hi-Rel's Grid Tied Solar Inverters are based on the contemporary technology of Hitachi Ltd, Japan. Currently Hitachi branded Solar Inverters are generating more than 5.5 GW renewable power in Global Solar Domain as well as more than 3 GW+ renewable power in Indian Solar Domain.

Sprawling across an area of 26,000 sq. meter and modelled on Hitachi's Omika Works in Japan, Hitachi Hi-Rel's Sanand manufacturing works is the world class and one of the most modern power electronics manufacturing facility in India. All aspects of manufacturing, testing and quality assurance are supported by highly experienced Japanese Expats stationed at the facility. Sanand Works employs Hitachi Omika Works (Japan) based software tools for engineering and manufacturing and has one of the most advanced product testing facilities in the country. Innovation through research & development has been rooted in its DNA. Hitachi Hi-Rel also has an additional facility at Gandhinagar near Ahmedabad in Gujarat which is sprawled across an area of 5,000 sq. meter. Its new products are developed by the R&D team which are on par with global standards. Along with indigenisation of products from Hitachi, original design of UPS and railway products are done regularly by the in-house R&D team.

With expertise, experience and an efficient product line, Hitachi Hi-Rel will always try to be your power electronics partner. When you choose to do business with Hitachi Hi-Rel, you are partnering with a company who cares.



## Worldwide Presence

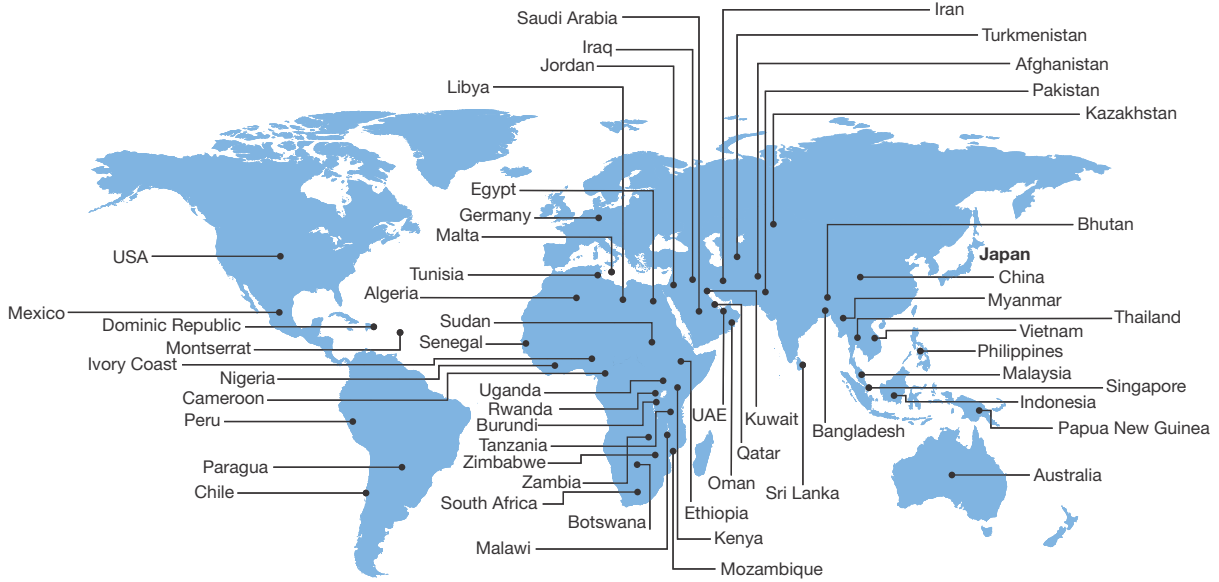

## Pan India Presence



## Contact us

### Hitachi Hi-Rel Power Electronics Private Limited

#### Registered Office:

B-52, Corporate House,  
Near Judges Bungalow, Bodakdev,  
Ahmedabad - 380 054, Gujarat, India.  
Tel: +91-79-6604 6200,  
Fax: +91-79-6604 6243

#### Manufacturing Works:

Plot No. SM 3 & 4, Sanand GIDC - II,  
Industrial Estate, Bol Village,  
Sanand - 382 110, Gujarat, India.  
Tel: +91-2717-678 777,  
Fax: +91-2717-678 700

#### Gandhinagar Facility:

B - 14/1 & 171, GIDC Electronics Zone,  
Sector - 25, Gandhinagar - 382 028,  
Gujarat, India.  
Tel: +91-79-6170 0500

 **Helpline No.:** (080) 6112 0800 (For Sales & Service)

 [contact@hitachi-hirel.com](mailto:contact@hitachi-hirel.com)

 [www.hitachi-hirel.com](http://www.hitachi-hirel.com)

 /company/hitachihirel

 /hitachihirelindia

 /hitachihirel



e-gallery